

FIG.1

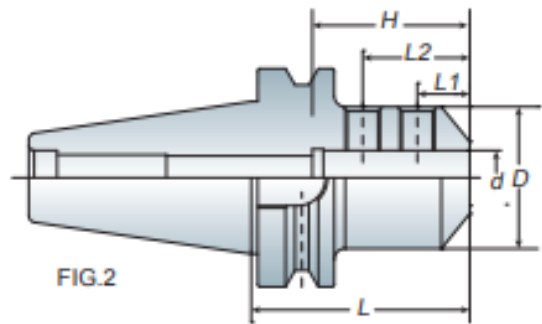

FIG.2



Features

- For straight shank end mill.
- End mill is held by one (FIG.1) or two (FIG.2) set screws.
- End mill holder comes equipped with set screws.

Model No.	FIG.	d	D	L	L1	L2	H	Weight (kg)
BT30 EM06-050	1	6	25	50	18	-	27	0.55
EM08-050	1	8	28	50	18	-	32	0.60
EM10-050	1	10	35	50	20	-	35	0.70
EM12-050	1	12	42	50	22.5	-	42	0.75
EM16-063	1	16	48	63	24	-	50	0.90
EM20-070	1	20	52	70	25	-	60	1.10
BT40 EM06-050	1	6	25	50	18	-	28	1.15
EM08-050	1	8	28	50	18	-	32	1.15
EM10-063	1	10	35	63	20	-	35	1.30
EM12-063	1	12	42	63	22.5	-	42	1.40
EM16-063	1	16	48	63	24	-	50	1.40
EM20-063	1	20	52	63	25	-	60	1.45
EM25-090	2	25	65	90	24	49	65	2.20
EM32-100	2	32	72	100	24	52	70	2.70

- Vise, mordazas o prensas angulares y basculantes

Vise con ajuste mecánico o hidráulico para taladros, fresadoras y centros de mecanizado CNC. Disponibles desde 4", 5", 6", 8"